



**STRONG PARTNERS.
TOUGH TRUCKS.™**



J45-70XN SERIES TECHNICAL GUIDE

WWW.HYSTER.COM

> J45-70XN DIMENSIONS

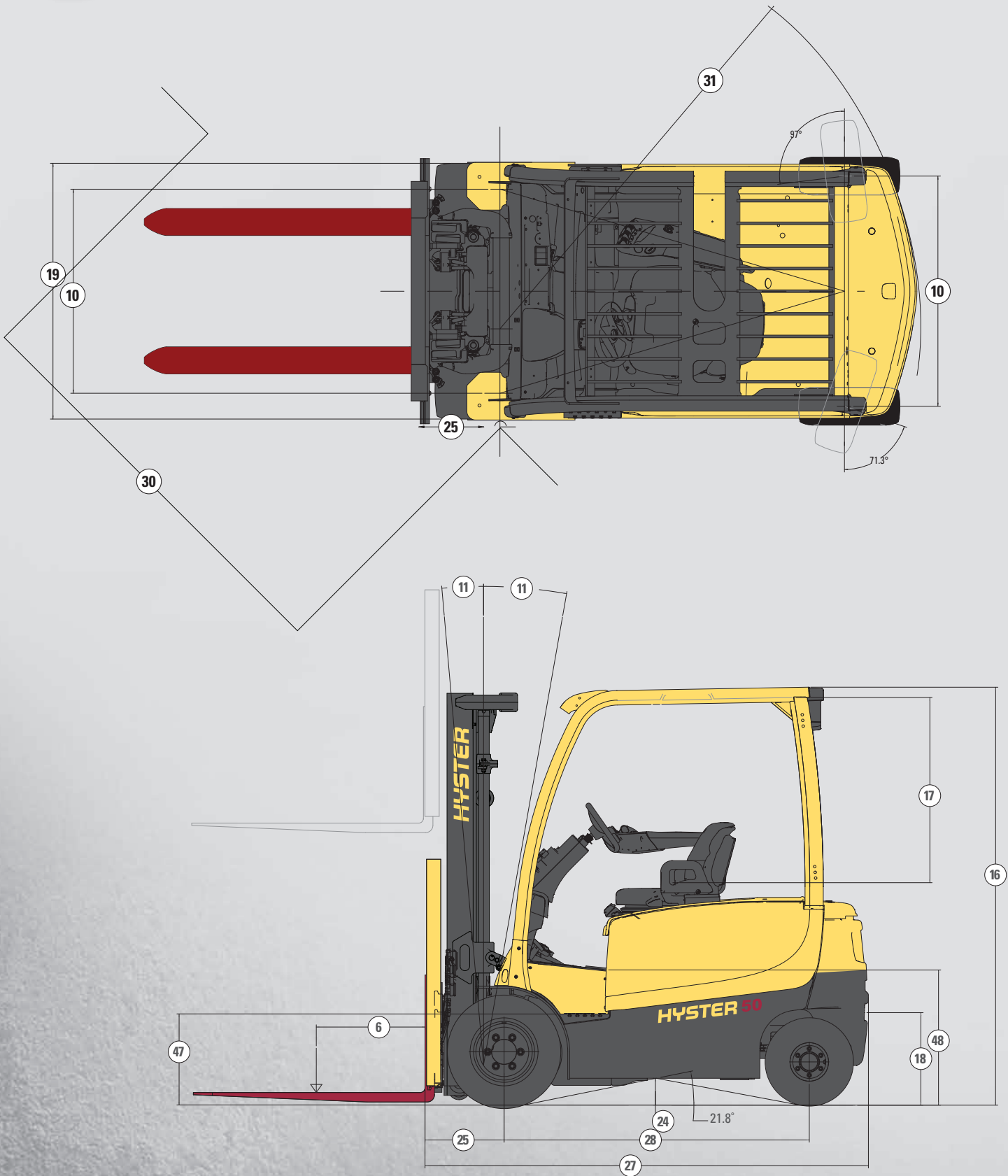

Circled dimensions correspond to the line numbers on the tabulated chart inside the Technical Guide. Dimensions are in inches (millimeters).

J45XN SPECIFICATIONS <

GENERAL	1	Manufacturer		Hyster Company			
	2	Model Designation		J45XN			
	3	Power/Voltage		Electric / 80 Volts			
	4	Operation		Sit			
	5	Rated Capacity	lb (kg)	4500 (2041)			
	6	Load Center	in (mm)	24 (610)			
TIRES	7	Tire Type (Std/Opt)		Pneumatic / Pneumatic Shaped Solid			
	8	Tire Size (Drive/Steer)		23 x 10 - 12 / 18 x 7 - 8			
	9	Wheels – Number X=Driven (Drive/Steer)		front/rear 2X / 2			
DIMENSIONS	10	Tread	Ctr. of Tires	Std Dr/Wide Dr/Steer	in (mm)	36.9 / 41.5 / 39.1 (938 / 1054 / 992)	
	11	Mast Tilt	Std Opt Opt		degrees	5F / 5B 10F / 5B 5F / 6B	
	12	Mast - Lowered Height	Std Mast		in (mm)	87 (2192)	
	13	Free Lift - Top of Fork	Std 2 Stg Limited Free Lift Mast		in (mm)	5 (140)	
	14	Lift Height - Top of Fork	Opt 2 Stg Full Free Lift Mast with/without LBR		in (mm)	37 / 64 (962 / 1628)	
	15	Mast - Extended Height	Std 2 Stg Limited Free Lift Mast		in (mm)	133 (3392)	
	16	Mast - Extended Height	Std Mast with/without LBR		in (mm)	182 / 156 (4622 / 3956)	
	17	Overhead Guard Height	Without/With Battery Rollers		in (mm)	86.3 / 90.4 (2193 / 2297)	
	18	SIP to Bottom of OHG	Seat Depressed	Std/Susp/Swivel		in (mm)	38.8 / 39.4 / 38.9 (986 / 1001 / 989)
	19	Tow Pin Height	Vertical Center of Pin		in (mm)	10.3 (262)	
	19	Overall Width	Pneumatic Tires	Std/Wide Tread	in (mm)	46.9 / 51.5 (1192 / 1308)	
	19		PSS Tires	Std/Wide Tread	in (mm)	46.2 / 50.7 (1173 / 1289)	
	20	Forks	Thickness x Width x Length		in (mm)	1.6 x 3.9 x 42 (40 x 100 x 1067)	
	21	Standard Carriage Width			in (mm)	42 (1067)	
	22	Floor to Bottom of Battery (Vertical / Roller / Forks)			in (mm)	5.7 (145) / 10.2 (259 / 9.9 (252)	
	23	Ground Clearance	Lowest Point (NL/RL)			in (mm)	3.9 / 3.3 (98 / 83)
	24	Ground Clearance	Center of Truck (NL/RL)		in (mm)	5.4 / 5.3 (137 / 135)	
	25	Load Distance	Center of Wheel to Face of Forks		in (mm)	15.9 (404)	
	25		NOMINAL SIZE			28" 34"	
	27	Length to Face of Forks	Chassis Length		in (mm)	91.4 (2321)	
	28	Wheelbase			in (mm)	63.2 (1606)	
	29	Right Angle Stack			in (mm)	141.3 (3588)	
	30	Equal Aisle	90° Intersecting Aisle		in (mm)	78 (1982)	
	31	Outside Turning Radius			in (mm)	76 (1931)	
	WT.	32	Truck Weight	Without Battery (NL)		lb (kg)	6740 (3057)
		33	Axle Loading - Drive	Static with Max. Wt. Battery (NL/RL)		lb (kg)	5756 / 13087 (2611 / 5936)
		34	Axle Loading - Steer	Static with Max. Wt. Battery (NL/RL)		lb (kg)	5121 / 2286 (2323 / 1037)
PERFORMANCE	35	Travel Speed	(NL/RL)	mph (km/h)	Standard Performance	PowerPlus Performance	
	36	Lift Speed	Std 2 Stg LFL Mast (NL/RL)	ft/min (m/sec)	11.2 / 11.2 (18 / 18)	13 / 13 (21 / 21)	
	36		Opt 2 Stg FFL Mast (NL/RL)	ft/min (m/sec)	124 / 79 (0.63 / 0.4)	142 / 102 (0.72 / 0.52)	
	36		Opt 3 Stg FFL Mast (NL/RL)	ft/min (m/sec)	124 / 81 (0.63 / 0.41)	130 / 98 (0.66 / 0.5)	
	37	Lower Speed	Std 2 Stg LFL Mast (NL/RL)	ft/min (m/sec)	124 / 79 (0.63 / 0.4)	134 / 100 (0.68 / 0.51)	
	37		Opt 2 Stg FFL Mast (NL/RL)	ft/min (m/sec)	100 / 112 (0.51 / 0.57)	91 / 102 (0.46 / 0.52)	
	37		Opt 3 Stg FFL Mast (NL/RL)	ft/min (m/sec)	93 / 106 (0.47 / 0.54)		
	38	Gradability	5 Minute Rating (NL/RL)	%	39 / 26	42 / 28	
	38		60 Minute Rating (NL/RL)	%	13 / 9	14 / 10	
	39	Drawbar Pull	5 Minute Rating (NL/RL)	lbf	4283 / 4057	4626 / 4462	
39	60 Minute Rating (NL/RL)		lbf	1298 / 1229	1402 / 1357		
40	Brake	Method of Control (Service/Parking)		Hydraulic / Mechanical			
40		Method of Operation (Service/Parking)		Foot / Automatic			
ELECTRIC	41	Battery	Type		Lead Acid		
	42	Traction Motors (Dual)	60 Minute Rating (Each)		hp (kW)	13.4 (10) 13.4 (10)	
	43	Pump Motor	15 Minute Rating		hp (kW)	21.5 (16) 32.2 (24)	
	44	Traction Motors	Type/Control Method		Dual AC / Transistor		
	45	Pump Motor	Type/Control Method		AC / Transistor		
	46	Number of Speeds	Traction/Pump		Infinitely Variable / Infinitely Variable		
OTHER	47	Step Height			in (mm)	18.7 (475)	
	48	Floor Height	Without/With Battery Rollers		in (mm)	27.8 / 31.9 (706 / 810)	
	49	Attachment Relief Pressure			psi (bar)	2250 (155)	
	50	Auxiliary Oil Flow	3rd and 4th Function		gal/min (l/min)	11 (40)	
	51	Sound Level	Measured per ANSI B56.11.5		dB (A)	63 65	

CERTIFICATION: Hyster lift trucks meet the design and construction requirements of B56.1-1969, per OSHA Section 1910.178(a)(2), and also comply with the B56.1 revision in effect at time of manufacture. Certification of compliance with the applicable ANSI standards appears on the lift truck.

NOTE: Performance specifications / ratings are for truck equipped as described under Standard Equipment in this Technical Guide. Performance specifications are affected by the condition of the vehicle and how it is equipped, as well as by the nature and condition of the operating area. Specifications are subject to change and the proposed application should be discussed with your authorized Hyster Company Dealer.

J50XN SPECIFICATIONS

GENERAL	1	Manufacturer		Hyster Company		
	2	Model Designation		J50XN		
	3	Power/Voltage		Electric / 80 Volts		
TIRES	4	Operation		Sit		
	5	Rated Capacity		lb (kg) 5000 (2268)		
	6	Load Center		in (mm) 24 (610)		
DIMENSIONS	7	Tire Type (Std/Opt)		Pneumatic / Pneumatic Shaped Solid		
	8	Tire Size (Drive/Steer)		in 23 x 10 - 12 / 18 x 7 - 8		
	9	Wheels – Number X=Driven (Drive/Steer)		front/rear 2X / 2		
DIMENSIONS	10	Tread	Ctr. of Tires Std Dr/Wide Dr/Steer	in (mm) 36.9 / 41.5 / 39.1 (938 / 1054 / 992)		
	11	Mast Tilt	Std Opt Opt	degrees 5F / 5B 10F / 5B 5F / 6B		
	12	Mast - Lowered Height	Std Mast	in (mm) 87 (2192)		
	13	Free Lift - Top of Fork	Std 2 Stg Limited Free Lift Mast	in (mm) 5 (140)		
	14	Lift Height - Top of Fork	Std 2 Stg Limited Free Lift Mast	in (mm) 133 (3392)		
	15	Mast - Extended Height	Std Mast with/without LBR	in (mm) 182 / 156 (4622 / 3956)		
	16	Overhead Guard Height	Without/With Battery Rollers	in (mm) 86.3 / 90.4 (2193 / 2297)		
	17	SIP to Bottom of OHG	Seat Depressed Std/Susp/Swivel	in (mm) 38.8 / 39.4 / 38.9 (986 / 1001 / 989)		
	18	Tow Pin Height	Vertical Center of Pin	in (mm) 10.3 (262)		
	19	Overall Width	Pneumatic Tires	Std/Wide Tread	in (mm) 46.9 / 51.5 (1192 / 1308)	
	20		PSS Tires	Std/Wide Tread	in (mm) 46.2 / 50.7 (1173 / 1289)	
	20	Forks	Thickness x Width x Length		in (mm) 1.6 x 3.9 x 42 (40 x 100 x 1067)	
	21	Standard Carriage Width			in (mm) 42 (1067)	
	22	Floor to Bottom of Battery (Vertical / Roller / Forks)			in (mm) 5.7 (145) / 10.2 (259) / 9.9 (252)	
	23	Ground Clearance	Lowest Point (NL/RL)		in (mm) 3.9 / 3.3 (98 / 83)	
	24	Ground Clearance	Center of Truck (NL/RL)		in (mm) 5.4 / 5.3 (137 / 134)	
	25	Load Distance	Center of Wheel to Face of Forks		in (mm) 15.9 (404)	
	27	Length to Face of Forks	Chassis Length	NOMINAL SIZE	28" 34"	
	27	Length to Face of Forks			in (mm) 91.4 (2321) 97 (2465)	
	28	Wheelbase			in (mm) 63.2 (1606) 68.9 (1750)	
	29	Right Angle Stack			in (mm) 141.3 (3588) 146.7 (3727)	
	30	Equal Aisle	90° Intersecting Aisle		in (mm) 78 (1982) 80.5 (2045)	
	31	Outside Turning Radius			in (mm) 76 (1931) 81.6 (2073)	
	WT.	32	Truck Weight	Without Battery (NL)	lb (kg) 6673 (3027) 7092 (3217)	
		33	Axle Loading - Drive	Static with Max. Wt. Battery (NL/RL)	lb (kg) 5681 / 13834 (2577 / 6275) 6563 / 14061 (2977 / 6378)	
34		Axle Loading - Steer	Static with Max. Wt. Battery (NL/RL)	lb (kg) 5130 / 1980 (2327 / 898) 5844 / 2954 (2651 / 1340)		
PERFORMANCE	35	Travel Speed	(NL/RL)	mph (km/h) 11.2 / 11.2 (18 / 18) 13 / 13 (21 / 21)		
	36	Lift Speed	Std 2 Stg LFL Mast (NL/RL)	ft/min (m/sec) 124 / 75 (0.63 / 0.38) 142 / 96 (0.72 / 0.49)		
	36		Opt 2 Stg FFL Mast (NL/RL)	ft/min (m/sec) 124 / 77 (0.63 / 0.39) 130 / 93 (0.66 / 0.47)		
	36		Opt 3 Stg FFL Mast (NL/RL)	ft/min (m/sec) 124 / 77 (0.63 / 0.39) 134 / 94 (0.68 / 0.48)		
	37	Lower Speed	Std 2 Stg LFL Mast (NL/RL)	ft/min (m/sec) 100 / 112 (0.51 / 0.57)		
	37		Opt 2 Stg FFL Mast (NL/RL)	ft/min (m/sec) 91 / 106 (0.46 / 0.54)		
	37		Opt 3 Stg FFL Mast (NL/RL)	ft/min (m/sec) 93 / 108 (0.47 / 0.55)		
	38	Gradability	5 Minute Rating (NL/RL)	% 35 / 24 38 / 26		
	38		60 Minute Rating (NL/RL)	% 12 / 8 13 / 9		
	39	Drawbar Pull	5 Minute Rating (NL/RL)	lbf 4248 / 4148 4588 / 4480		
39	60 Minute Rating (NL/RL)		lbf 1287 / 1257 1390 / 1357			
40	Brake	Method of Control (Service/Parking)		Hydraulic / Mechanical		
ELECTRIC	41	Battery	Type	Foot / Automatic Lead Acid		
	42	Traction Motors (Dual)	60 Minute Rating (Each)	hp (kW) 13.4 (10) 13.4 (10)		
	43	Pump Motor	15 Minute Rating	hp (kW) 21.5 (16) 32.2 (24)		
	44	Traction Motors	Type/Control Method	Dual AC / Transistor		
	45	Pump Motor	Type/Control Method	AC / Transistor		
	46	Number of Speeds	Traction/Pump	Infinitely Variable / Infinitely Variable		
	47	Step Height			in (mm) 18.7 (475)	
OTHER	48	Floor Height	Without/With Battery Rollers	in (mm) 27.8 / 31.9 (706 / 810)		
	49	Attachment Relief Pressure			psi (bar) 2250 (155)	
	50	Auxiliary Oil Flow	3rd and 4th Function		gal/min (l/min) 11 (40)	
	51	Sound Level	Measured per ANSI B56.11.5		dB (A) 63 65	

CERTIFICATION: Hyster lift trucks meet the design and construction requirements of B56.1-1969, per OSHA Section 1910.178(a)(2), and also comply with the B56.1 revision in effect at time of manufacture. Certification of compliance with the applicable ANSI standards appears on the lift truck.

NOTE: Performance specifications / ratings are for truck equipped as described under Standard Equipment in this Technical Guide. Performance specifications are affected by the condition of the vehicle and how it is equipped, as well as by the nature and condition of the operating area. Specifications are subject to change and the proposed application should be discussed with your authorized Hyster Company Dealer.

J60XN SPECIFICATIONS <

GENERAL	1	Manufacturer		Hyster Company		
	2	Model Designation		J060XN		
	3	Power/Voltage		Electric / 80 Volts		
	4	Operation		Sit		
	5	Rated Capacity	lb (kg)	6000 (2722)		
	6	Load Center	in (mm)	24 (610)		
TIRES	7	Tire Type (Std/Opt)		Pneumatic / Pneumatic Shaped Solid		
	8	Tire Size (Drive/Steer)		23 x 10 - 12 / 18 x 7 - 8		
	9	Wheels – Number X=Driven (Drive/Steer)		front/rear 2X / 2		
DIMENSIONS	10	Tread	Ctr. of Tires Std Dr/Wide Dr/Steer	in (mm) 36.9 / 41.5 / 39.1 (938 / 1054 / 992)		
	11	Mast Tilt	Std Opt Opt	degrees 5F / 5B 10F / 5B 5F / 6B		
	12	Mast - Lowered Height	Std Mast	in (mm) 87 (2192)		
	13	Free Lift - Top of Fork	Std 2 Stg Limited Free Lift Mast		in (mm) 5 (140)	
			Opt 2 Stg Full Free Lift Mast with/without LBR		in (mm) 37 / 60 (957 / 1540)	
	14	Lift Height - Top of Fork	Std 2 Stg Limited Free Lift Mast		in (mm) 126 (3209)	
	15	Mast - Extended Height	Std Mast with/without LBR		in (mm) 175 / 153 (4444 / 3861)	
	16	Overhead Guard Height	Without/With Battery Rollers		in (mm) 86.3 / 90.4 (2193 / 2297)	
	17	SIP to Bottom of OHG	Seat Depressed Std/Susp/Swivel	in (mm) 38.8 / 39.4 / 38.9 (986 / 1001 / 989)		
	18	Tow Pin Height	Vertical Center of Pin		in (mm) 10.3 (262)	
	19	Overall Width	Pneumatic Tires	Std/Wide Tread	in (mm) 46.9 / 51.5 (1192 / 1308)	
			PSS Tires	Std/Wide Tread	in (mm) 46.2 / 50.7 (1173 / 1289)	
	20	Forks	Thickness x Width x Length		in (mm) 2 x 4.9 x 42 (50 x 125 x 1067)	
	21	Standard Carriage Width			in (mm) 42 (1067)	
	22	Floor to Bottom of Battery (Vertical / Roller / Forks)				in (mm) 5.7 (145) / 10.2 (259) / 9.9 (252)
	23	Ground Clearance	Lowest Point (NL/RL)		in (mm) 3.9 / 3.3 (98 / 83)	
	24	Ground Clearance	Center of Truck (NL/RL)		in (mm) 5.4 / 5.3 (137 / 134)	
	25	Load Distance	Center of Wheel to Face of Forks		in (mm) 16.4 (416)	
			NOMINAL SIZE		34	
	27	Length to Face of Forks	Chassis Length		in (mm) 97 (2465)	
	28	Wheelbase			in (mm) 68.9 (1750)	
29	Right Angle Stack			in (mm) 146.7 (3727)		
30	Equal Aisle	90° Intersecting Aisle		in (mm) 80.5 (2045)		
31	Outside Turning Radius			in (mm) 81.6 (2073)		
WT.	32	Truck Weight	Without Battery (NL)	lb (kg) 7143 (3240)		
	33	Axle Loading - Drive	Static with Max. Wt. Battery (NL/RL)		lb (kg) 6228 / 14919 (2825 / 6767)	
	34	Axle Loading - Steer	Static with Max. Wt. Battery (NL/RL)		lb (kg) 5838 / 2648 (2648 / 1201)	
PERFORMANCE	35	Travel Speed	(NL/RL)	mph (km/h) 11.2 / 10.6 (18 / 17)		
	36	Lift Speed	Std 2 Stg LFL Mast (NL/RL)	ft/min (m/sec) 116 / 65 (0.59 / 0.33)		
			Opt 2 Stg FFL Mast (NL/RL)	ft/min (m/sec) 108 / 65 (0.55 / 0.33)		
			Opt 3 Stg FFL Mast (NL/RL)	ft/min (m/sec) 112 / 65 (0.57 / 0.33)		
	37	Lower Speed	Std 2 Stg LFL Mast (NL/RL)	ft/min (m/sec) 91 / 110 (0.46 / 0.56)		
			Opt 2 Stg FFL Mast (NL/RL)	ft/min (m/sec) 73 / 102 (0.37 / 0.52)		
			Opt 3 Stg FFL Mast (NL/RL)	ft/min (m/sec) 79 / 104 (0.4 / 0.53)		
	38	Gradability	5 Minute Rating (NL/RL)	% 34 / 22		
			60 Minute Rating (NL/RL)	% 11 / 7		
	39	Drawbar Pull	5 Minute Rating (NL/RL)	lbf 4146 / 4037		
60 Minute Rating (NL/RL)			lbf 1256 / 1223			
40	Brake	Method of Control (Service/Parking)		Hydraulic / Mechanical		
		Method of Operation (Service/Parking)		Foot / Automatic		
ELECTRIC	41	Battery	Type	Lead Acid		
	42	Traction Motors (Dual)	60 Minute Rating (Each)	hp (kW) 13.4 (10)		
	43	Pump Motor	15 Minute Rating	hp (kW) 21.5 (16)		
	44	Traction Motors	Type/Control Method	Dual AC / Transistor		
	45	Pump Motor	Type/Control Method	AC / Transistor		
	46	Number of Speeds	Traction/Pump	Infinitely Variable / Infinitely Variable		
OTHER	47	Step Height		in (mm) 18.7 (475)		
	48	Floor Height	Without/With Battery Rollers	in (mm) 27.8 / 31.9 (706 / 810)		
	49	Attachment Relief Pressure		psi (bar) 2250 (155)		
	50	Auxiliary Oil Flow	3rd and 4th Function	gal/min (l/min) 11 (40)		
	51	Sound Level	Measured per ANSI B56.11.5		dB (A) 63 65	

CERTIFICATION: Hyster lift trucks meet the design and construction requirements of B56.1-1969, per OSHA Section 1910.178(a)(2), and also comply with the B56.1 revision in effect at time of manufacture. Certification of compliance with the applicable ANSI standards appears on the lift truck.

NOTE: Performance specifications / ratings are for truck equipped as described under Standard Equipment in this Technical Guide. Performance specifications are affected by the condition of the vehicle and how it is equipped, as well as by the nature and condition of the operating area. Specifications are subject to change and the proposed application should be discussed with your authorized Hyster Company Dealer.

J70XN SPECIFICATIONS

GENERAL	1	Manufacturer		Hyster Company	
	2	Model Designation		J70XN	
	3	Power/Voltage		Electric / 80 Volts	
	4	Operation		Sit	
	5	Rated Capacity		7000 (3175)	
	6	Load Center		24 (610)	
TIRES	7	Tire Type (Std/Opt)		Pneumatic / Pneumatic Shaped Solid	
	8	Tire Size (Drive/Steer)		23 x 10 - 12 / 18 x 7 - 8	
	9	Wheels – Number X=Driven (Drive/Steer)		front/rear 2X / 2	
DIMENSIONS	10	Tread	Ctr. of Tires Std Dr/Wide Dr/Steer	in (mm)	36.9 / 41.5 / 39.1 (938 / 1054 / 992)
	11	Mast Tilt	Std Opt Opt	degrees	5F / 5B 10F / 5B 5F / 6B
	12	Mast - Lowered Height	Std Mast	in (mm)	87 (2192)
	13	Free Lift - Top of Fork	Std 2 Stg Limited Free Lift Mast	in (mm)	5 (140)
			Opt 2 Stg Full Free Lift Mast with/without LBR	in (mm)	37 / 60 (957 / 1540)
	14	Lift Height - Top of Fork	Std 2 Stg Limited Free Lift Mast	in (mm)	126 (3209)
	15	Mast - Extended Height	Std Mast with/without LBR	in (mm)	175 / 153 (4444 / 3861)
	16	Overhead Guard Height	Without/With Battery Rollers	in (mm)	86.3 / 90.4 (2193 / 2297)
	17	SIP to Bottom of OHG	Seat Depressed Std/Susp/Swivel	in (mm)	38.8 / 39.4 / 38.9 (986 / 1001 / 989)
	18	Tow Pin Height	Vertical Center of Pin	in (mm)	10.3 (262)
	19	Overall Width	Pneumatic Tires Std/Wide Tread	in (mm)	46.9 / 51.5 (1192 / 1308)
			PSS Tires Std/Wide Tread	in (mm)	46.2 / 50.7 (1173 / 1289)
	20	Forks	Thickness x Width x Length	in (mm)	2 x 4.9 x 42 (50 x 125 x 1067)
	21	Standard Carriage Width		in (mm)	42 (1067)
	22	Floor to Bottom of Battery (Vertical / Roller / Forks)		in (mm)	5.7 (145) / 10.2 (259) / 9.9 (252)
	23	Ground Clearance	Lowest Point (NL/RL)	in (mm)	3.9 / 3.3 (98 / 83)
	24	Ground Clearance	Center of Truck (NL/RL)	in (mm)	5.4 / 5.2 (137 / 132)
	25	Load Distance	Center of Wheel to Face of Forks	in (mm)	16.4 (416)
			Nominal	SIZE	34
	27	Length to Face of Forks	Chassis Length	in (mm)	100.5 (2555)
	28	Wheelbase		in (mm)	68.9 (1750)
	29	Right Angle Stack		in (mm)	149.3 (3793)
	30	Equal Aisle	90° Intersecting Aisle	in (mm)	81.7 (2074)
	31	Outside Turning Radius		in (mm)	84.2 (2139)
	WT.	32	Truck Weight	Without Battery (NL)	lb (kg)
33		Axle Loading - Drive	Static with Max. Wt. Battery (NL/RL)	lb (kg)	6177 / 17275 (2802 / 7836)
34		Axle Loading - Steer	Static with Max. Wt. Battery (NL/RL)	lb (kg)	6744 / 2648 (3059 / 1201)
PERFORMANCE	35	Travel Speed	(NL/RL)	mph (km/h)	Standard Performance 11.2 / 9.9 (18 / 16) PowerPlus Performance 13 / 11.2 (21 / 18)
	36	Lift Speed	Std 2 Stg LFL Mast (NL/RL)	ft/min (m/sec)	116 / 61 (0.59 / 0.31) 124 / 73 (0.63 / 0.37)
			Opt 2 Stg FFL Mast (NL/RL)	ft/min (m/sec)	108 / 61 (0.55 / 0.31) 116 / 73 (0.59 / 0.37)
			Opt 3 Stg FFL Mast (NL/RL)	ft/min (m/sec)	112 / 61 (0.57 / 0.31) 118 / 73 (0.6 / 0.37)
	37	Lower Speed	Std 2 Stg LFL Mast (NL/RL)	ft/min (m/sec)	91 / 114 (0.46 / 0.58)
			Opt 2 Stg FFL Mast (NL/RL)	ft/min (m/sec)	73 / 106 (0.37 / 0.54)
			Opt 3 Stg FFL Mast (NL/RL)	ft/min (m/sec)	79 / 110 (0.4 / 0.56)
	38	Gradability	5 Minute Rating (NL/RL)	%	32 / 20 35 / 22
			60 Minute Rating (NL/RL)	%	10 / 6 11 / 7
	39	Drawbar Pull	5 Minute Rating (NL/RL)	lbf	4243 / 4064 4583 / 4389
	60 Minute Rating (NL/RL)		lbf	1286 / 1232 1389 / 1330	
40	Brake	Method of Control (Service/Parking)		Hydraulic / Mechanical	
		Method of Operation (Service/Parking)		Foot / Automatic	
ELECTRIC	41	Battery	Type		Lead Acid
	42	Traction Motors (Dual)	60 Minute Rating (Each)	hp (kW)	13.4 (10) 13.4 (10)
	43	Pump Motor	15 Minute Rating	hp (kW)	21.5 (16) 32.2 (24)
	44	Traction Motors	Type/Control Method		Dual AC / Transistor
	45	Pump Motor	Type/Control Method		AC / Transistor
	46	Number of Speeds	Traction/Pump		Infinitely Variable / Infinitely Variable
OTHER	47	Step Height		in (mm)	18.7 (475)
	48	Floor Height	Without/With Battery Rollers	in (mm)	27.8 / 31.9 (706 / 810)
	49	Attachment Relief Pressure		psi (bar)	2250 (155)
	50	Auxiliary Oil Flow	3rd and 4th Function	gal/min (l/min)	11 (40)
	51	Sound Level	Measured per ANSI B56.11.5	dB (A)	63 65

CERTIFICATION: Hyster lift trucks meet the design and construction requirements of B56.1-1969, per OSHA Section 1910.178(a)(2), and also comply with the B56.1 revision in effect at time of manufacture. Certification of compliance with the applicable ANSI standards appears on the lift truck.

NOTE: Performance specifications / ratings are for truck equipped as described under Standard Equipment in this Technical Guide. Performance specifications are affected by the condition of the vehicle and how it is equipped, as well as by the nature and condition of the operating area. Specifications are subject to change and the proposed application should be discussed with your authorized Hyster Company Dealer.

J45-50XN MAST DIMENSIONS

Maximum Fork Height (TOF)	Overall Lowered Ht.	Overall Extended Height w/Load Backrest	Overall Extended Height w/o Load Backrest	Free-Lift (TOF) w/Load Backrest	Free-Lift (TOF) w/o Load Backrest	Truck Weight	
						J45XN	J50XN
in. (mm)	in. (mm)	in. (mm)	in. (mm)	in. (mm)	in. (mm)		
2-STAGE LIMITED FREE-LIFT (LFL) VISTA® MAST							
133 (3392)	87 (2192)	182 (4622)	156 (3956)	5 (140)	5 (140)	6305	6305
141 (3592)	91 (2292)	190 (4822)	164 (4156)	5 (140)	5 (140)	6335	6335
2-STAGE FULL FREE-LIFT (FFL) VISTA® MAST							
133 (3402)	87 (2192)	183 (4632)	157 (3966)	37 (962)	64 (1628)	6350	6350
141 (3602)	91 (2292)	191 (4832)	164 (4166)	41 (1062)	68 (1728)	6380	6380
3-STAGE FULL FREE-LIFT (FFL) VISTA® MAST							
183 (4650)	81 (2042)	232 (5880)	205 (5196)	32 (812)	58 (1496)	6645	6645
189 (4800)	83 (2092)	238 (6030)	211 (5346)	33 (862)	60 (1546)	6665	6665
194 (4950)	85 (2142)	244 (6180)	217 (5496)	35 (912)	62 (1596)	6690	6690
200 (5100)	89 (2242)	250 (6330)	223 (5646)	39 (1012)	66 (1696)	6735	6735
206 (5250)	91 (2292)	256 (6480)	229 (5796)	41 (1062)	68 (1746)	6765	6765
212 (5400)	93 (2342)	261 (6630)	235 (5946)	43 (1112)	70 (1796)	6790	6790

J60-70XN MAST DIMENSIONS

Maximum Fork Height (TOF)	Overall Lowered Ht.	Overall Extended Height w/Load Backrest	Overall Extended Height w/o Load Backrest	Free-Lift (TOF) w/Load Backrest	Free-Lift (TOF) w/o Load Backrest	Truck Weight	
						J60XN	J70XN
in. (mm)	in. (mm)	in. (mm)	in. (mm)	in. (mm)	in. (mm)		
2-STAGE LIMITED FREE-LIFT (LFL) VISTA® MAST							
126 (3209)	87 (2192)	175 (4444)	152 (3861)	5 (150)	5 (150)	6655	7345
134 (3409)	91 (2292)	183 (4644)	160 (4061)	5 (150)	5 (150)	6690	7380
2-STAGE FULL FREE-LIFT (FFL) VISTA® MAST							
126 (3210)	87 (2192)	175 (4445)	152 (3862)	37 (957)	60 (1540)	6700	7390
134 (3410)	91 (2292)	183 (4645)	160 (4062)	41 (1057)	64 (1640)	6730	7420
3-STAGE FULL FREE-LIFT (FFL) VISTA® MAST							
181 (4618)	85 (2142)	231 (5853)	207 (5252)	35 (907)	59 (1508)	7030	7720
187 (4768)	89 (2242)	237 (6003)	213 (5402)	39 (1007)	63 (1608)	7085	7775
193 (4918)	91 (2292)	243 (6153)	219 (5552)	41 (1057)	65 (1658)	7105	7795
205 (5218)	95 (2392)	255 (6453)	231 (5852)	45 (1157)	69 (1758)	7160	7850
217 (5518)	101 (2542)	266 (6753)	243 (6152)	51 (1307)	75 (1908)	7340	8030

BATTERY AND COMPARTMENT SPECIFICATIONS

Model	Compartment Size			Battery Specifications									
				Electrical				Size			Weight		
	W in (mm)	L in (mm)	H in (mm)	Volts	No. of Cells	Plates per Cell	Max Am Hr (kWh)	W Max in (mm)	L Max in (mm)	H Max in (mm)	Min lbs (kg)	Max lbs (kg)	
J45-50XN 28" Compartment	Vertical Extract	40.7 (1034)	28.2 (717)	31.2 (792)	80	40	9	1000 (77.6)	40.5 (1028)	28.0 (711)	30.9 (784)	3700 (1886)	4100 (1878)
	Horizontal Removal - Roller	40.7 (1034)	28.2 (717)	31.1 (789)					40.5 (1028)	28.0 (711)	30.8 (782)		
	Horizontal Removal - Forklift	40.4 (1028)	28.0 (712)	31.3 (796)					40.4 (1026)	27.8 (706)	31.0 (788)		
50-70XN 34" Compartment	Vertical Extract	40.7 (1034)	33.9 (861)	31.2 (792)	80	40	11	1000 (77.6)	40.5 (1028)	33.7 (855)	30.9 (784)	4500 (2021)	4900 (2233)
	Horizontal Removal - Roller	40.7 (1034)	33.9 (861)	31.1 (789)					40.5 (1028)	33.7 (855)	30.8 (782)		
	Horizontal Removal - Forklift	40.4 (1028)	33.7 (856)	31.3 (796)					40.4 (1026)	33.5 (850)	31.0 (788)		

Battery Type: "EO" (Without Cover)
 Battery amp hr (kwh) capacity is max allowable per UL
 Commercially available lead acid batteries may not necessarily reach these max limits
 Battery Compartment Length is measured front to rear. Battery Compartment Width is measured across the truck

Battery Notes - Conventional Charging (Opt BC320A)
 Battery Connector: 80 volt - Black (Anderson Power Products® SBE®320 P/N 6363G1 or REMA® SRE 320 P/N 78350-05)
 Battery Lead: Length 30" (762 mm), Position "A", 2/0 AWG

Battery Notes - Rapid / Fast Charging (Opt BARQCS)
 Battery Connector: Requires Positive / Negative Cabling terminating in (1) Female EBC-320 DIN Connector
 (Anderson Power Products® P/N E32503-00X9 or REMA® 95625-X1)
 DIN connector to include 1 Red Conductor to (+) and 1 black conductor to (-)
 Battery Lead: Length 36" (915 mm), Position "A", Minimum Cable Size 3/0 AWG

Battery Notes - Premium, Fully Integrated "Quick Connect" Rapid / Fast Charging
 Battery Connector: Requires Positive / Negative Cabling terminating in (1) Female EBC-320 DIN Connector
 (Anderson Power Products® P/N E32503-00X9 or REMA® 95625-X1)
 DIN connector to include 1 Red Conductor to (+) and 1 black conductor to (-)
 Battery Lead: Length 36" (915 mm), Position "A", Minimum Cable Size 3/0 AWG

STANDARD EQUIPMENT

- 2-Stage Limited Free Lift (LFL) Vista™ Mast with Maximum Fork Height of 133" (3392mm) (J45-50XN) or 126" (3209mm) (J60-70XN)
- 5° Forward and 5° Back Mast Tilt
- 42" (1067mm) Wide Class II (J45-50XN) or Class III (J60-70XN) Hook-type Carriage with 48" (1219mm) High Load Backrest Extension
- 42" (1067mm) Long Forks
- Pneumatic Drive Tire and Steer Tire
- Battery Compartment Size: 28" (J45-50XN); 34" (J60-70XN)
- Lift Out Battery Extraction
- 80 Volt Electrical System
- Standard Performance
- Standard Construction
- Dual Drive Motors
- Oil-Cooled Wet Disc Brakes
- UL Classification Type "E"
- 12" Steering Wheel with Integral Spinner Knob
- Non-Suspension Vinyl Seat
- Black ELR Non-Cinch Seat Belt
- Automatic Park Brake
- Key Switch Start
- 86.3" Grid Style Overhead Guard
- MONOTROL™ Foot Direction Control
- 3 Function Hydraulic Control Valve with Seat Side Mechanical Levers
- AC Traction and Pump Motors (Completely Brushless)
- Transistor Drive and Pump Control
- Advanced VSM (Vehicle System Manager)
- Progressive Thermal Management System
- Fully Integrated CANbus Communication
- On-Demand Power Steering
- Hyster Stability Mechanism™
- Power Assist Braking
- ADS (Auto Deceleration System) with Regenerative Braking
- "Zero Turn" Steer Axle
- Multifunction Display
 - Battery State of Charge with Low Battery Lift Interrupt
 - Hour Meter
 - Performance Mode Indicator
 - Fault Indicator (Audible & Visible)
 - 4 Operator Selectable, Programmable Performance Modes
- Easy Ingress / Egress with Low Step Height and Contoured Handhold
- Operator Convenience Station - Storage Areas, Beverage & Clipboard Holders
- Adjustable Tilt Steering Column with Low Profile Cowl for Excellent Visibility
- Operator Presence System (OPS)
- Anti Cinch Operator Restraint System
- Cushioned Floormat
- Static Strap
- Tow Pin
- Seatside Power Disconnect Button
- Battery Side Covers
- On-Board Software
 - Program, Test & Diagnose
 - Password Protected
- Electronic Horn with Integral Relay (Long Life / No Adjustments)
- 24 Month / 4,000 Hour Powertrain Warranty
- 12 Month / 2,000 Hour Full Truck Warranty
- Operating Manual

OPTIONAL EQUIPMENT

- Side Extraction Battery Removal with Rollers
- 34" Battery Compartment for the J50XN
- PowerPlus Performance
- Rapid / Fast Charge
- UL Classification Type "EE"
- Available with 2-stage Limited Free Lift (LFL) and 2- or 3-stage Full Free Lift (FFL) Vista™ Masts
- Carriage with Integral Sideshift
- Carriage with Integral Sideshifting Fork Positioner
- Mast Tilt Option – 10° Forward / 5° Back
- Mast Tilt Option – 5° Forward / 6° Back
- Return to Set Tilt
- Accumulator
- TouchPoint Hydraulic Mini-levers with Fully Adjustable Armrest
- 4 Function Hydraulic Control Valve
- Solid Pneumatic Tires
- Wide Tread Tires
- Non-Suspension Seat (Cloth)
- Full Suspension Seat (Vinyl or Cloth)
- Swivel Seat, Full Suspension (Vinyl or Cloth)
- Full Steel Cab: Includes Front Panel with Wiper / Washer, Rear Panel with Wiper / Washer, Steel Doors, Top Panel with Headliner and Dome Light
- Front and Top Cab Panels: Includes Front Panel with Wiper / Washer and Top Panel
- Keyless Start (with Auxiliary Key Switch)
- Seat Side Directional Control
- Telescopic Steering Column with Tilt Memory
- LED and Halogen work light packages
- LED Dome / Reading Light
- LED Brake / Tail / Back-Up light packages
- Audible Reverse Activated Alarm
- Visible Amber Strobe Light - Continuous Activated, Overhead Guard Mounted
- Rear Drive Handle with Integrated Horn Button
- Mirrors – Rear View or Panoramic
- Load Weight Indicator
- Impact Monitor
- Operator Password
- Operator Daily Checklist
- System Monitor – Hydraulic Low Fluid Level Indicator and Hydraulic Filter Service Indicator
- Hydraulic Attachment Extension Tubes with or without Quick Disconnect Fittings
- Fire Extinguisher – 2.5 lb. Dry Chemical
- Synchronous Steering
- Red (HI-VIS) ELR (Emergency Locking Retractor) Non-cinch Seat Belt
- Red (HI-VIS) ELR (Emergency Locking Retractor) Non-cinch Seat Belt with Start Interlock
- Low Mount Display
- Integrated Rapid Charge
- IP54 Sealed Drive Axle/Motors with Belly Pan and Side Shields
- Outdoor Protection / Wash-Down Package
- Front Mud Guards
- Tilt Cylinder Boots



Hyster Company
P.O. Box 7006
Greenville, North Carolina
27835-7006
Part No. J45-70XN/TG
6/2018 Litho in U.S.A.

Visit us online at www.hyster.com or call us at **1-800-HYSTER-1**.

Hyster, , and STRONG PARTNERS. TOUGH TRUCKS. and MONOTROL are registered trademarks in the United States and certain other jurisdictions. Hyster products are subject to change without notice.

Trucks may be shown with optional equipment. © 2018 Hyster Company. All rights reserved.